

CEILING RECESS KIT (SOLD SEPARATELY)

1. Prepare ceiling cut out & ceiling box.
Ceiling box minimum internal dimensions must be as shown in table.
Heater must be installed with heater surface at least 2400mm above the floor level.

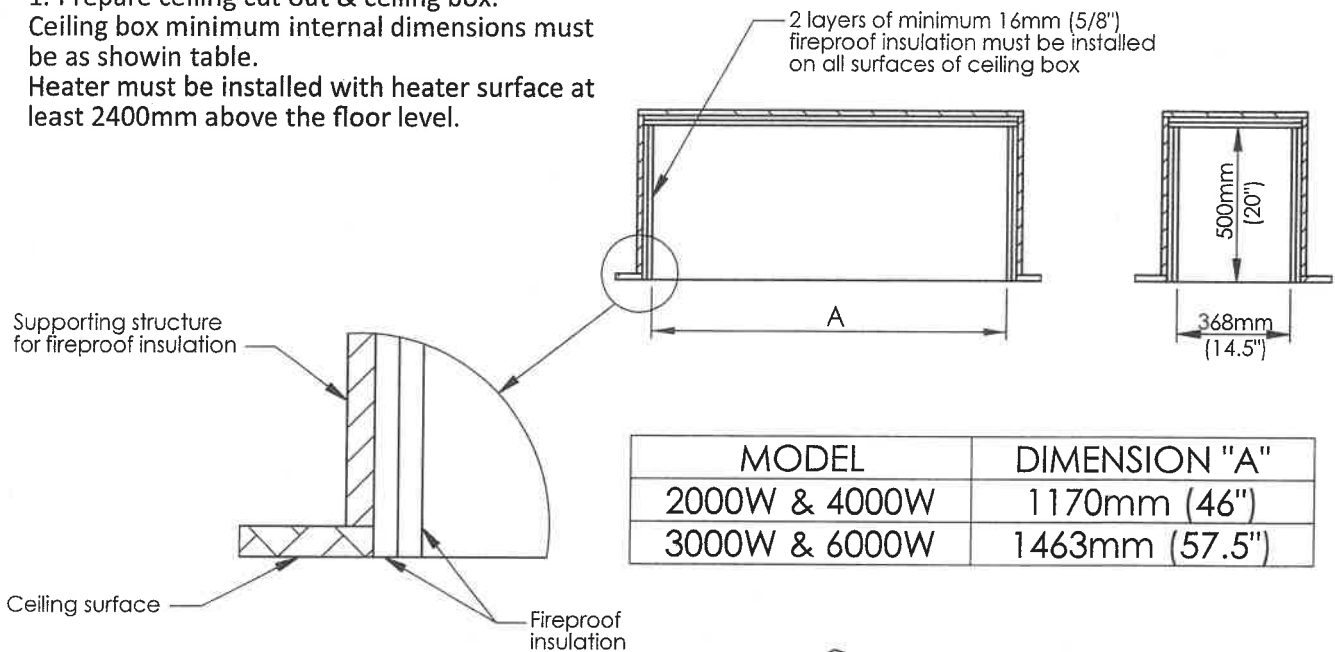

MODEL	DIMENSION "A"
2000W & 4000W	1170mm (46")
3000W & 6000W	1463mm (57.5")

2. From below, bring ceiling frame up and into ceiling cut out.
3. Fasten ceiling frame to ceiling box through mounting holes with fasteners (not supplied).

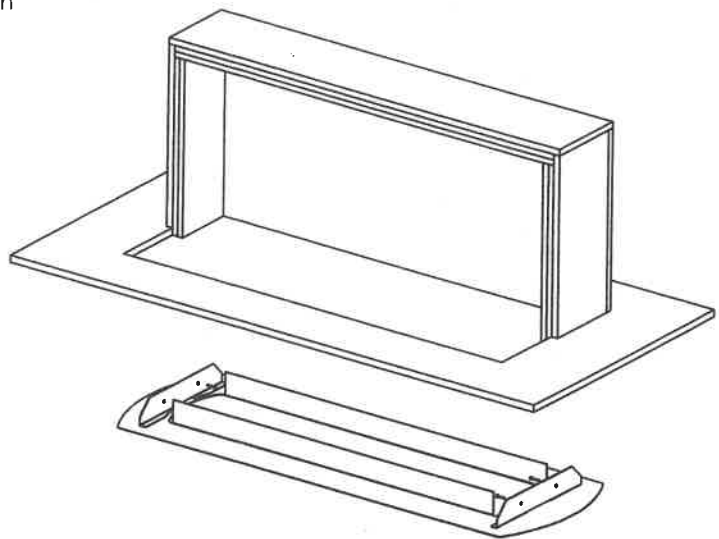

4. Prepare heater for installation
Attach mounting brackets to both ends of heater with supplied fasteners

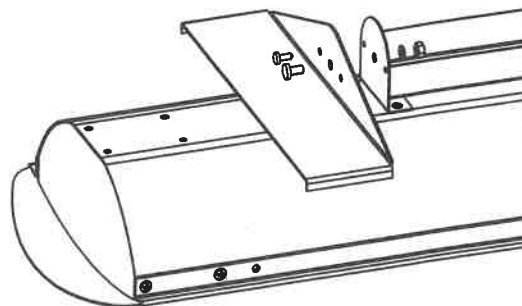

6. Assemble supplied terminal blocks, wire, conduit & junction box cover.

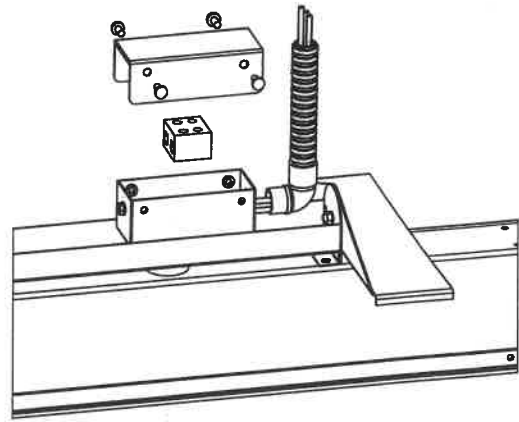

7. Raise one side of heater up into the ceiling box & then raise whole heater into cavity.

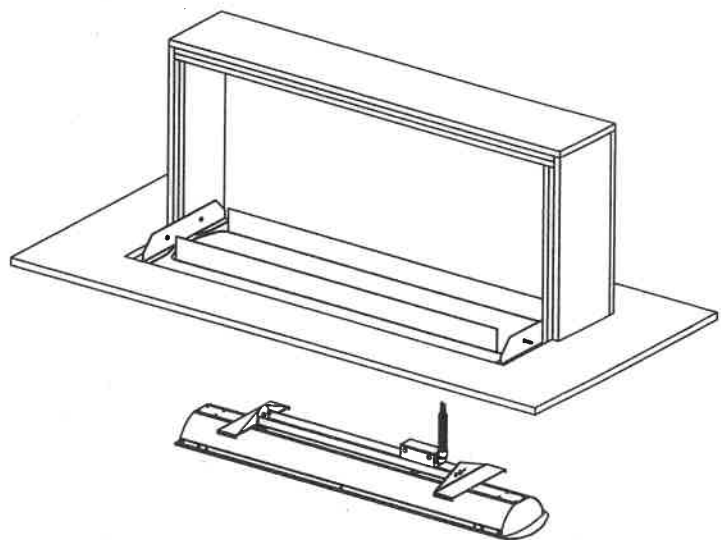

8. Rotate the heater into horizontal position in the ceiling box & then lower down onto the ceiling frame.

9. Ensure all four side mounting brackets are hooked over the ceiling frame & centre the heater inside the frame.

10. Make electrical connection from heater to power supply. Connection to be made outside on the side or top of the ceiling box.

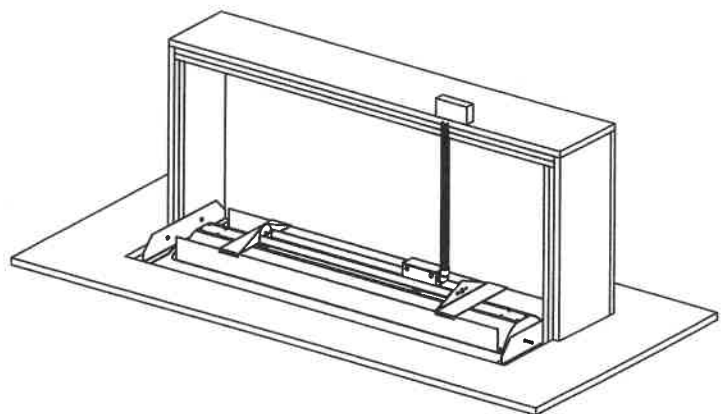

BROMIC
HEATING

BROMIC HEATING

V1.0 Last Edited 07/01/2014

Head Office: 1 Suttor Street, Silverwater, Sydney, NSW 2128 Australia

Telephone: 1300 276 642 (within Australia) or +61 2 9748 3900 (from overseas) **Fax:** +61 2 9748 4289

Email: info@bromicheating.com **Web:** www.bromicheating.com

Note: Bromic Heating reserves the right to make changes to specifications, parts, components and equipment without prior notification. This Installation, operation and service manual may not be reproduced in any form with prior written consent from Bromic Heating.